

# AIR-150

## 26 TOPS AI Inference System Intel 13<sup>th</sup> Gen. with Hailo-8 AI

NEW



### Features

- 13th gen. Intel Core i3/i5 up to 14 Watt with 10 Cores
- Empowered by Hailo-8 M.2 AI module up to 26 TOPS
- Compact Fanless 156 x 112 x 60mm dimensions
- Dual 4K lockable HDMI 2.0b, 4096x2160 resolution
- Vertical I/O: 3x COM/1x DIO/2x CANBus/2x LAN/4x USB
- Rich AI toolkits for runtime integration and model deployment
- Flexible expansion with 3x M.2:  
M key 2280 (NVMe storage),  
E key 2230 (Wi-Fi),  
B key 3042 (Hailo AI)
- Suitable for Industrial usage:  
-20~60°C wide temperature and 12-24V wide voltage support

WISE-DeviceOn HAILO EdgeAI SDK LISTED C-UL US CE FC

### Specifications

Name		AIR-150-S44A1	AIR-150-S24A1
Processor System	CPU	Core i5-1345UE	Core i3-1315UE
	System Chipset	Integrated in CPU	
Memory	Technology	Dual Channel DDR5 5200 MHz 262 pin SO-DIMM	
	Capacity	Max. capacity 64GB	
Graphics	Chipset	Intel® Iris® Xe Graphics eligible	Intel® UHD Graphics for 13th Gen Intel® Processors
	Graphic Engine	Direct X 12.1, OpenGL 4.6	
		HW Encode: H.265/HEVC, H.264/AVC, VP9, SCC HW Decode: H.265/HEVC, H.264/AVC, VP9, SCC	
	HDMI	2x HDMI 2.0b: 4096x2160@60Hz, Dual Display	
Storage	SSD/M.2	SATA Slim M-Key 2280 (SATA, PCIe4 Gen.4 NVMe)	
	I/O Interface	LAN1	10/100/1000 Mbps Intel i219 1GbE
LAN2		100/1000/2500 Mbps Intel i226 2.5 GbE	
USB 2.0/USB 3.2		1/3	
Audio		1 x Mic-in / Line-out, Realtek ALC888S HD Audio	
COM		2 x RS-232/422/485 1x RS-485 (COM3)	
DIO		DB9 8 bit, 1 port	
CANBus		2x3 pin, 2 ports	
Expansion		M.2	1 x E-Key 2230 (PCIex1, USB2.0) 1 x B-Key 3042/3052 w/ Nano SIM (PCIex1, USB 3.2) *Default bundled with Hailo AI module B+M key 1 x M-Key 2280 (SATA, PCIe4)
Trusted Platform Module	TPM 2.0	SLB9670XQ2.0 (on board)	
Power Requirement	Power Input Voltage	12-24 V <sub>DC</sub>	
	Power Type	ATX/AT mode (Default ATX)	
Power Consumption	Typical (OS idle mode)	17.9W	
	Max. (Full loading)	45.81W	
Physical Characteristics	Mounting	Wall Mounting/Din-Rail	
	Dimensions (W x H x D)	156 x 112 x 60 mm	
	Weight	1.3 kg	
Environment	Operating Temperature	-20 ~ 60 °C, with 0.7m/s air flow	
	Storage Temperature	-40 ~ 85 °C (-40 ~ 185°F)	
	Relative Humidity	95% @ 40 °C (non-condensing)	
	Vibration during Operation	3 Grms, IEC60068-2-64, random, 5-500 Hz, 1hr/axis (with Wall Mount)	
	Shock during Operation	30 G, IEC-60068-2-27, half sine, 11 ms duration (with Wall Mount)	
Software Support	Microsoft Windows	Windows 10/ Windows 11 IoT 64-bit	
	Linux	Ubuntu 22.04	
Certification	EMC	CE/FCC Class B, Heavy Industry 61000-6-4, 61000-6-2, CCC, BSMI	
	Safety	UL, CB, CCC, BSMI	

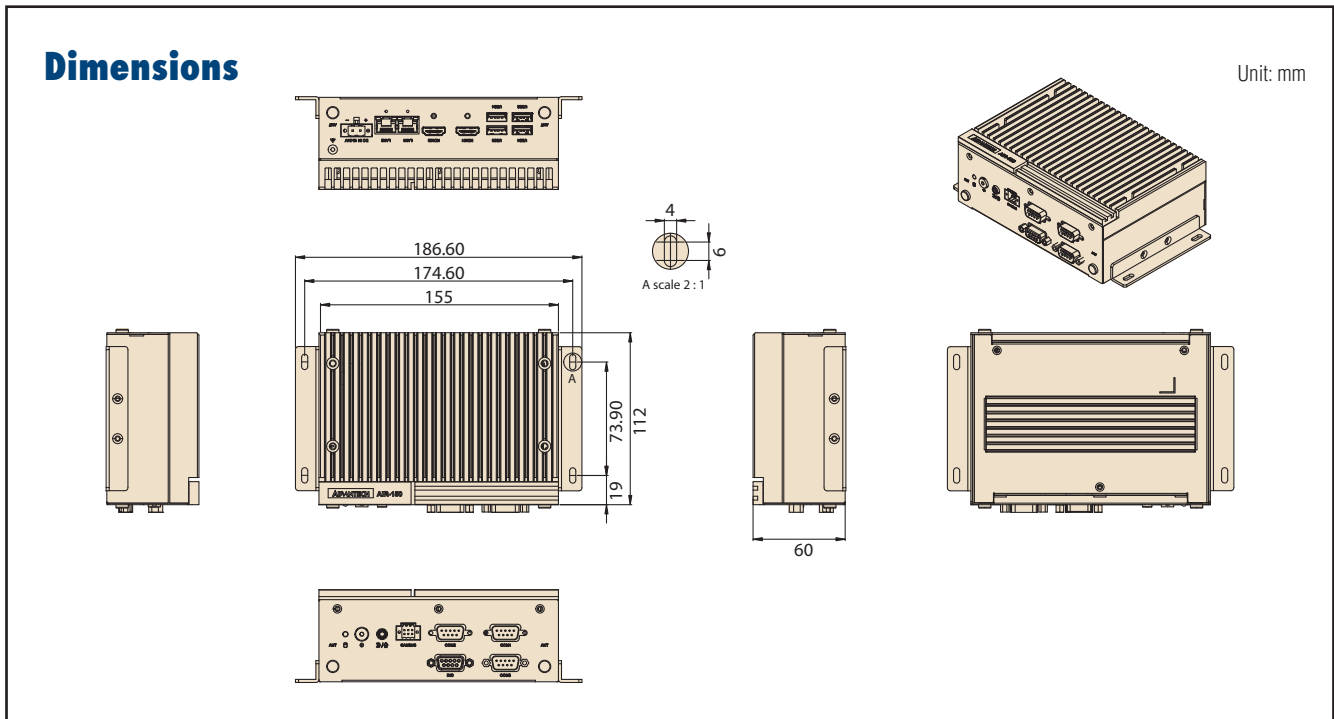

### Front View

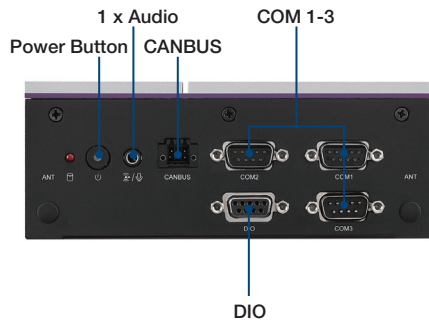

### Rear View

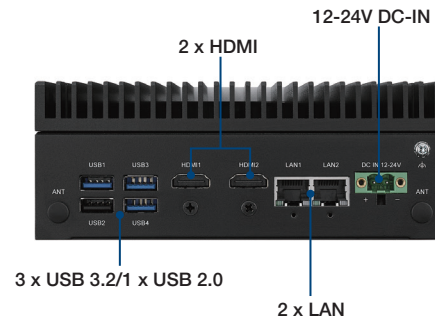

### Ordering Information

Part No.	CPU	Memory	Storage	Hailo AI module	Display	LAN	USB	CANbus	DIO	RS-232/422/485	M.2	Power Input	Operating Temp.	Audio
AIR-150-S44A1	Intel Core i5-1345UE	UP to 64GB	1x SATA Slim	1x M.2 B+M key 2242	2 x HDMI	2 (1GbE/2.5GbE)	3 x 3.2 1 x 2.0	2	1	3	E-key 2230 & B-Key 3042 & M-Key 2280	12-24 V <sub>DC</sub>	-20 ~ 60 °C	Mic-in/ Line-out
AIR-150-S24A1	Intel Core i3-1315UE	UP to 64GB	1x M-Key 2280											

\* System Made in Taiwan

### Packing List

Part Number	Description
-	1 x AIR-150 unit
1960052226N004	2 x Wallmount
2006R15000	1 x User manual (Simplified Chinese)
36WSWPD0BUND11	1 x WISE-DeviceOn Package
1652000099	1x Phoenix connector counterpart
1652008233-01	1x Canbus counterpart

### Optional Items

Part Number	Description
96PSA-A90W190T-3	90W Power Adaptor (19V DC in)
1700001524	Power Cable 3-pin 180cm, USA type
170203183C	Power Cable 3-pin 180cm, Europe type
170203180A	Power Cable 3-pin 180cm, UK type
1700008921	Power Cable 3-pin PSE Mark 183cm
AMK-R006E	DIN-Rail Mounting for EI-53

### Embedded OS

Part Number	Description
20706WX1VS0082	Win 10 IoT 64 bit w/ WISE Device-On Core i3/i5 SKU
20706U22DS0036	Ubuntu Desktop 22.04 LTS 64bit